



22146201



International Baccalaureate®
Baccalauréat International
Bachillerato Internacional

**DESIGN TECHNOLOGY
HIGHER LEVEL
PAPER 1**

Monday 19 May 2014 (afternoon)

1 hour

INSTRUCTIONS TO CANDIDATES

- Do not open this examination paper until instructed to do so.
- Answer all the questions.
- For each question, choose the answer you consider to be the best and indicate your choice on the answer sheet provided.
- The maximum mark for this examination paper is *[40 marks]*.

1. What scale of changes relates to incremental design and radical design?

	Incremental design	Radical design
A.	Small changes	Small changes
B.	Small changes	Large changes
C.	Large changes	Small changes
D.	Large changes	Large changes

2. Which model would allow for the evaluation of forces acting on a structure?

- A. Algorithm
- B. Flow chart
- C. Mathematical model
- D. Scale model

3. **Figure 1** shows a drawing of a guitar.

Figure 1: A drawing of a guitar

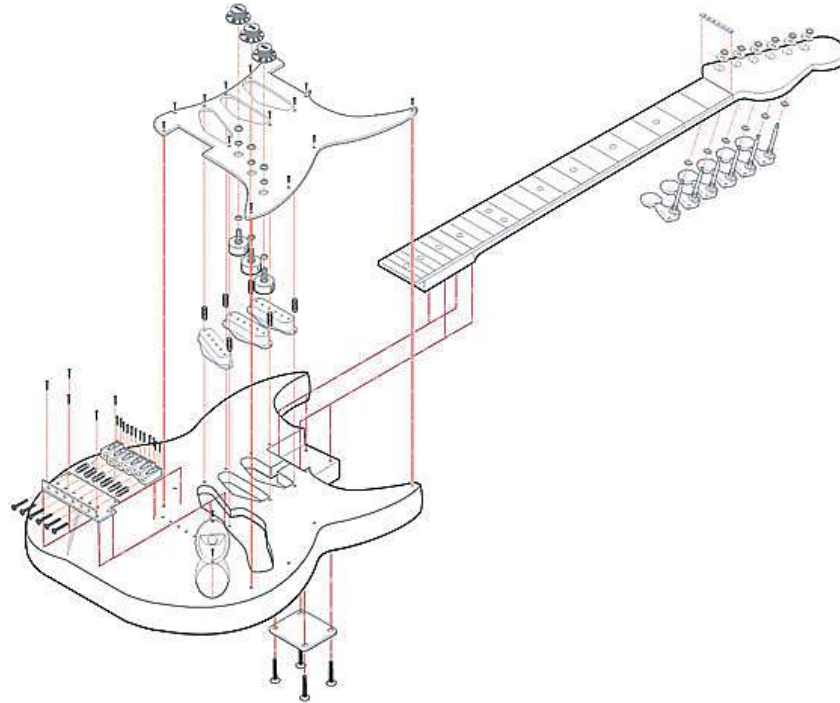

[Source: Reproduced with permission from tutsplus.com]

What is shown in **Figure 1**?

- A. The component parts of a product and how they fit together
- B. The sequence of assembly of the component parts of a product
- C. The size of the component parts of the product
- D. The detail needed for a production drawing

4. Which constraint in the design brief for a child’s toy has implications for fixed costs?
- A. Must use standard parts
 - B. Must have a small number of moving parts
 - C. Must be made of a low melting point thermoplastic
 - D. Must be produced by injection moulding
5. Which combination of product and market relates to the corporate strategy of diversification?

	Product	Market
A.	New	New
B.	New	Existing
C.	Existing	New
D.	Existing	Existing

6. **Figure 2** shows a model of the Apple iPad which was released in March 2012. The release date of the new iPad was brought forward by Apple.

Figure 2: A model of the Apple iPad released in March 2012

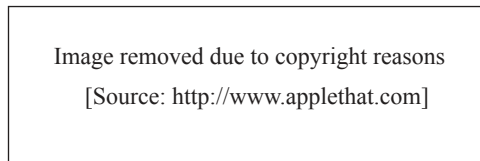

What impacts resulted from bringing the release date of the iPad forward?

- I. The product cycle for the iPad was shortened.
 - II. The iPad remained ahead of its competitors.
 - III. The company had to invest heavily in research and development.
- A. I and II only
 - B. I and III only
 - C. II and III only
 - D. I, II and III

- 7. The retail store Marks and Spencer has launched an initiative – ShwopDrop – to encourage people to reduce the volume of obsolete clothing sent to landfill (**Figure 3**). After collection the clothes are sold by the charity Oxfam in their shops.

Figure 3: Joanna Lumley launching an initiative designed to reduce the volume of obsolete clothing sent to landfill



[Source: ©Michael Bowles/REX. Used with permission.]

Which green design strategy will SchwopDrop promote?

- A. Recondition
- B. Recycle
- C. Repair
- D. Reuse

8. Which type of material is least likely to be able to be recycled economically?
- A. Composite
 - B. Glass
 - C. Metal
 - D. Thermoplastic

9. Figure 4 shows a map of the world.

Figure 4: A map of the world

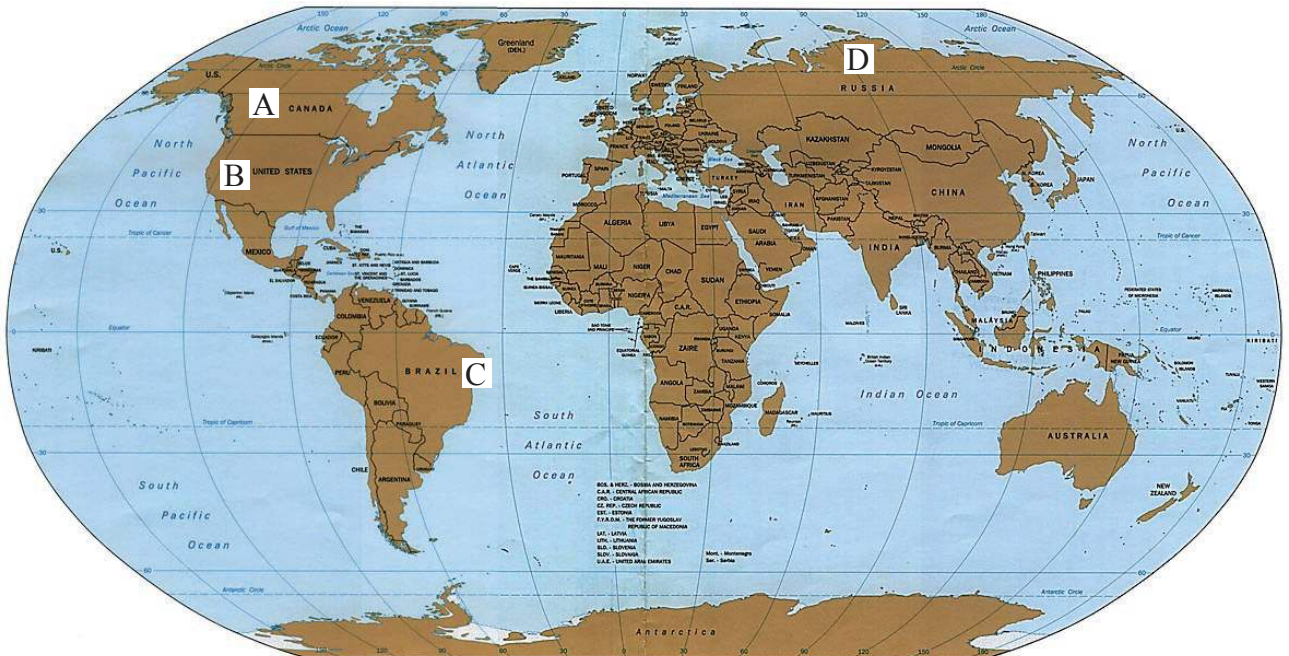

[Source: www.lib.utexas.edu.
Courtesy of the University of Texas Libraries, The University of Texas at Austin.]

In which region of the world do exotic hardwoods, for example mahogany, grow?

10. **Figure 5** shows workers at the Hyundai car plant in Beijing lining up pressed metal automobile (car) parts.

Figure 5: Pressed metal automobile (car) parts in the Hyundai car plant in Beijing



[Source: <http://auto.howstuffworks.com> ©PA. Used with permission.]

What property of the metal allows it to be pressed into the required shape for the automobile parts?

- A. Ductility
- B. Plasticity
- C. Elasticity
- D. Stiffness

11. **Figure 6** shows a child's wooden train set.

Figure 6: Child's wooden train set

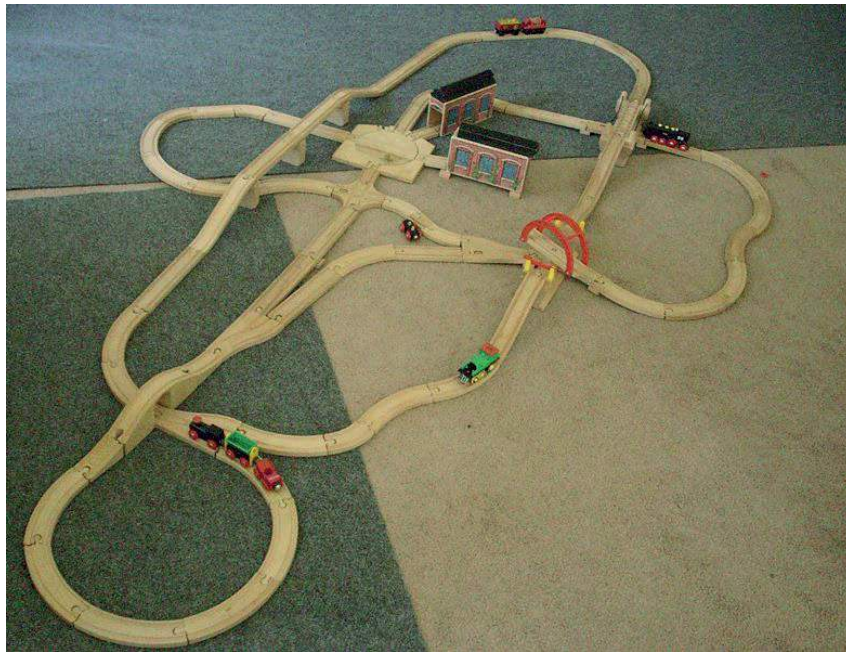

[Source: http://commons.wikimedia.org/wiki/File:783px-Brio_toy_train_track-1-.jpg]

Why would the timber for the train set need to be treated?

- A. To harden it
 - B. To colour it
 - C. To seal the grain
 - D. To toughen it
12. What type of composite material is used in the sensor of an airbag in a car?
- A. Shape memory alloy
 - B. Magneto-rheostatic
 - C. Electro-rheostatic
 - D. Piezoelectric

13. The composite material Kevlar[®] is weight-for-weight stronger than steel and less dense. What would be the implications of using Kevlar rather than steel for the cables of an elevator (lift)?
- A. The cable will be lighter
 - B. Increased capacity of the elevator
 - C. The pulley will need to be larger
 - D. Less maintenance required
14. Corning[®] Gorilla[®] Glass 2 has increased hardness compared to borosilicate glass. What is an advantage of using Corning Gorilla Glass 2 for display screens on electronic devices?
- A. Brighter displays
 - B. Enhanced scratch resistance
 - C. Greater touch sensitivity
 - D. Lighter devices

15. Ferrari is famous for its high performance sports cars which are produced to individual customer specifications (**Figure 7**). **Figure 8** shows a worker with a hand tool on the Ferrari assembly line.

Figure 7: A new Ferrari high performance sports car



Figure 8: The Ferrari assembly line



[Source: Images reproduced with permission from Ferrari.]

Which production systems are used to create the Ferrari car?

- I. Mechanization
 - II. Automation
 - III. Mass customization
- A. I and II only
 - B. I and III only
 - C. II and III only
 - D. I, II and III

16. **Figure 9** shows a graph of total costs and volume of production.

Figure 9: Graph of total costs and volume of production

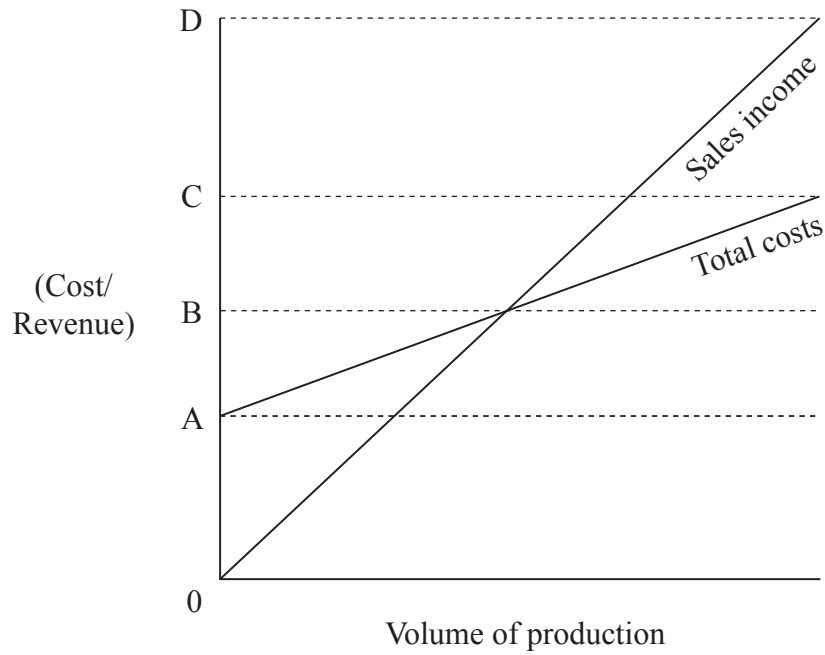

[Source: © International Baccalaureate Organization 2014]

Which of the following represents the variable costs at the “break-even point”?

- A. A
 - B. B–A
 - C. C–B
 - D. D–C
17. Which production process is the most flexible?
- A. Craft production
 - B. Mechanization
 - C. Assembly-line production
 - D. Mass customization

18. Which types of data would be used for comfort and room temperature?

	Comfort	Room temperature
A.	Qualitative data	Qualitative data
B.	Qualitative data	Quantitative data
C.	Quantitative data	Qualitative data
D.	Quantitative data	Quantitative data

19. What type of obsolescence relates to a product going out of fashion?

- A. Planned obsolescence
- B. Materials obsolescence
- C. Style obsolescence
- D. Technological obsolescence

20. **Figure 10** shows the Earpod headphones designed for the Apple iPhone 5. As part of the design development for the earphones, Apple invited over 600 people to test different designs while running on treadmills.

Figure 10: Apple iPhone 5 Earpod headphones

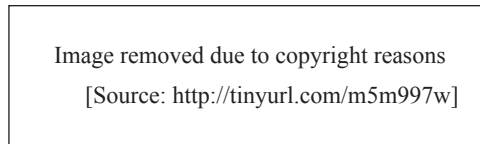

Which evaluation strategy was used in the development phase for the Apple iPhone 5 Earpod headphones?

- A. User research
 - B. User trial
 - C. Field trial
 - D. Expert appraisal
21. When do quality assurance and quality control activities take place for manufactured products?

	Quality assurance	Quality control
A.	Before manufacture	Before manufacture
B.	Before manufacture	After manufacture
C.	After manufacture	Before manufacture
D.	After manufacture	After manufacture

22. **Figure 11** shows a bus powered by bio-diesel – a biofuel produced from soybeans.

Figure 11: A bus powered by bio-diesel



[Source: <http://en.wikipedia.org/wiki/File:Soybeanbus.jpg>]

Which factor is definitely **not** a barrier to the expansion of this type of transport system?

- A. Availability of bio-diesel fuel stations
 - B. Availability of soybeans
 - C. Availability of technology to convert soybeans to bio-diesel fuel
 - D. Availability of land to grow the soybeans
23. A range of design considerations determines the selection of an appropriate battery for a portable product. Two considerations are self-discharge (loss of energy due to the internal leakage) and energy density (the ratio of the energy a battery can deliver to its weight).

Which combination of self-discharge and energy density would characterize the ideal battery for a travel clock?

	Self-discharge	Energy density
A.	Low	Low
B.	Low	High
C.	High	Low
D.	High	High

24. Why does a designer use a low factor of safety in the design of an aircraft?
- A. Regular inspection and maintenance is undertaken
 - B. Staff are highly trained
 - C. Risk control measures are in place
 - D. Strength-to-weight ratio is a critical issue
25. What is true of mass but **not** weight?
- A. It is measured in kilograms.
 - B. It is measured in Newtons.
 - C. It depends on gravity.
 - D. It can be zero.

26. **Figure 12** shows a stress/strain graph for a material.

Figure 12: Stress/strain graph

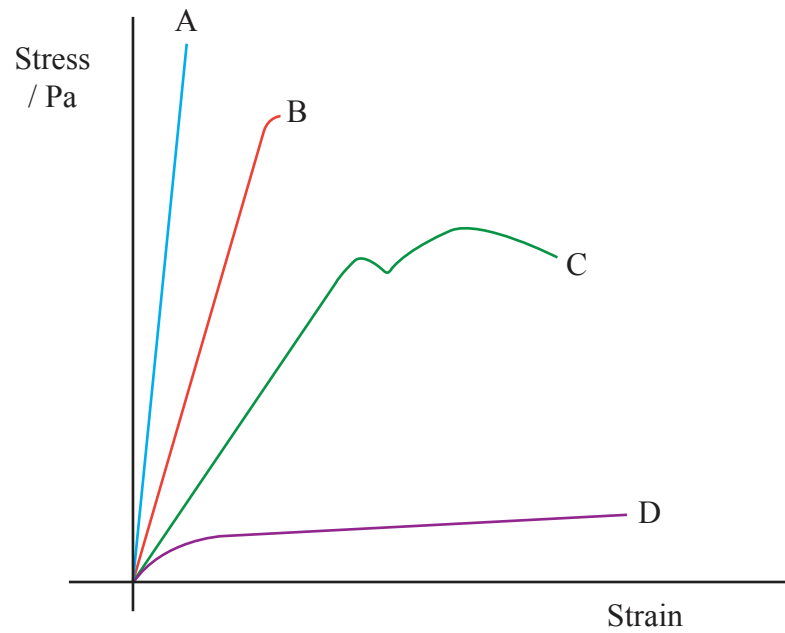

[Source: Reproduced with permission from www.cyberphysics.co.uk]

Which material is a plastic material?

27. A rack and pinion mechanism converts rotary motion into

- A. linear motion.
- B. rotary motion.
- C. intermittent motion.
- D. reciprocating motion.

28. Figure 13 shows a derailleur gear system on a bicycle.

Figure 13: Derailleur gear mechanism

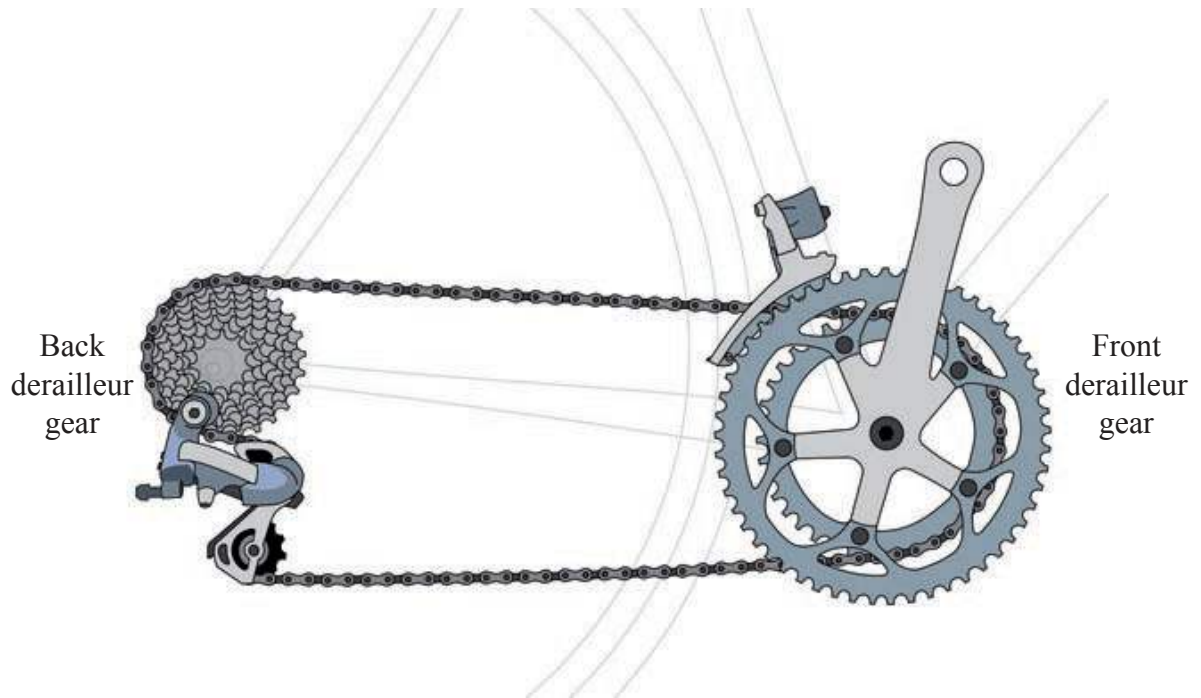

[Source: http://en.wikipedia.org/wiki/File:Derailleur_Bicycle_Drivetrain.svg; Created by Keithonearth]

Which combination of front and back derailleur gears would be most appropriate for climbing a steep hill?

	Front derailleur gear	Back derailleur gear
A.	Small	Small
B.	Small	Large
C.	Large	Small
D.	Large	Large

29. **Figure 14** is an annotated diagram of part of a screw thread. **Figure 15** shows the SCRW chair designed by Manuel Welsky. The seat is made from cork with a screw thread. It can be screwed into the aluminium base so that the height can be easily adjusted.

Figure 14: Part of a screw thread

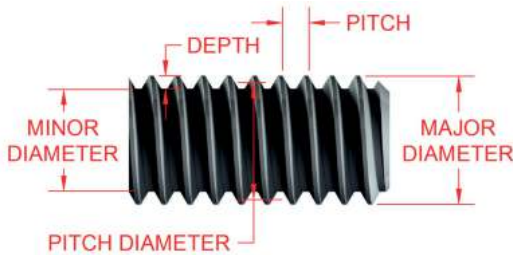

[Source: http://commons.wikimedia.org/wiki/File:Screw_Threads_2.png www.mechlook.com]

Figure 15: The SCRW chair



[Source: Reproduced with permission from the Manuel Welsky Design Studio. Photograph by Rolf Lang.]

What dimension in **Figure 14** represents the vertical height that the cork seat of the SCRW chair will move if it is turned by one complete revolution?

- A. Major diameter
- B. Pitch diameter
- C. Minor diameter
- D. Pitch

30. **Figure 16** shows a prosthesis used for hip replacements.

Figure 16: A hip prosthesis

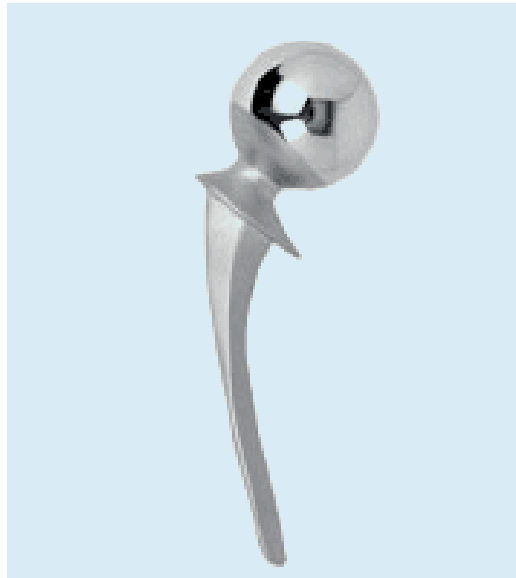

[Source:<http://commons.wikimedia.org/wiki/File:Hip-Prosthesis.png?uselang=en-gb>]

What is an advantage of using high-pressure die casting for creating a hip prosthesis?

- A. Suitable for a wide range of materials
 - B. Low cost
 - C. Good surface finish
 - D. Low hardness
31. Which adhesive is **not** suitable for joining wood?
- A. Epoxy resin
 - B. Tensol cement
 - C. Cascamite
 - D. Polyvinyl acetate (PVA)

32. Which plastic materials are typically used with compression moulding and injection moulding?

	Compression moulding	Injection moulding
A.	Thermoplastic	Thermoplastic
B.	Thermoplastic	Thermoset
C.	Thermoset	Thermoplastic
D.	Thermoset	Thermoset

33. What is a characteristic of socially-responsible design?

- A. Does not rely on finite resources
- B. Increased productivity
- C. Enhances ecosystem integrity
- D. Sustains cultural identity

34. Which combination of heat flow and U value would be most effective in buildings located in regions with large seasonal temperature variations?

	Heat flow	U value
A.	Low	Low
B.	Low	High
C.	High	Low
D.	High	High

35. What is **not** a characteristic of a passive solar system in a building?

- A. Thermal mass
- B. Appropriate solar orientation
- C. A pump
- D. Natural convection

Questions 36–40 relate to the following case study. Please read the case study carefully and answer the questions.

Around the world three billion people still cook on open indoor fires. Four million people die annually from the toxic emissions caused by these inefficient, smoky cooking fires. Women and children are particularly affected, spending hours in the kitchen daily. Alec Drummond and Jonathan Cedar of the US-based company, BioLite, have designed the BioLite HomeStove™ (Figure 17) to reduce indoor air pollution. BioLite’s pilot retail programs work with local leaders and sales agents in emerging markets to promote the product to communities. Revenue from BioLite’s recreational product family, sold in developed countries, help support the costs required to establish distribution and sales support in these emerging markets. The BioLite CampStove™ is the flagship product of the recreational division and its success has enabled long-term investment in the HomeStove program.

Figure 17: The BioLite HomeStove™



- Introducing The BioLite HomeStove™
- 50 % Less Wood Consumed
- Time and Cash Savings
- 95 % Smoke Reduction
- Improved Health
- Nearly Eliminates Black Carbon
- Protects Climate
- Generates Electricity
- Charges Phones & LED Lights



Figure 18: The BioLite CampStove™



Figure 19: How the CampStove™ works

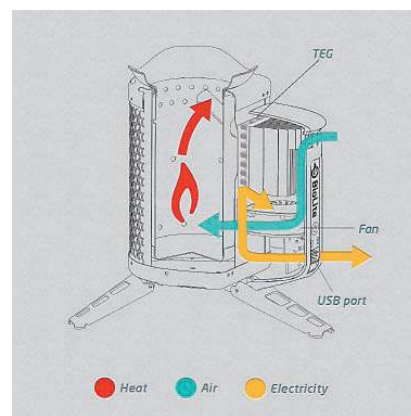

[Source: <http://biolitestove.com>. Used with permission.]

(Figures 18 and 19) Both the HomeStove and CampStove burn wood to produce a fire that can be used for cooking. The waste heat from the fire is converted into electricity via a thermoelectric generator. This powers an internal fan that circulates air back into the fire, making it burn more efficiently. Surplus electricity can charge a cell phone, LED lights, and other small devices off-grid via a USB port located on the powerpack.

36. What is a major advantage of the BioLite Homestove over a solar cooker?
- A. More cost-effective in use
 - B. Can be used at night
 - C. Uses solid fuel
 - D. No emission of greenhouse gases
37. Which characteristics of appropriate technology does the Biolite HomeStove meet?
- I. Is not detrimental to quality of life or the environment
 - II. Creates jobs using local skills and labour
 - III. Makes technology understandable to the people who use it
- A. I and II only
 - B. I and III only
 - C. II and III only
 - D. I, II and III
38. Which combination of heat and fuel use is achieved by the Biolite HomeStove?

	Heat	Fuel use
A.	Less	Less
B.	Less	More
C.	More	Less
D.	More	More

39. Which is an advantage to the BioLite organization of developing the Biolite HomeStove and the Biolite CampStove as a product family?
- A. Reduced productivity
 - B. Design constraints
 - C. Faster time-to-market
 - D. Reduced capital expenditure
40. Which cost related to the Biolite HomeStove is an example of a fixed cost?
- A. Material costs
 - B. Labour costs
 - C. Distribution costs
 - D. Marketing costs
-